

AVELLA™

WARRANTY * INSTALLATION * CARE

Porcelain, Ceramic and Natural Stone Tile



LIMITED RESIDENTIAL CONSUMER WARRANTY

Porcelain and Ceramic Tile Products

THIS LIMITED WARRANTY GIVES YOU SPECIFIC LEGAL RIGHTS, AND YOU MAY ALSO HAVE OTHER RIGHTS, WHICH VARY FROM STATE TO STATE AND PROVINCE TO PROVINCE.

THIS LIMITED WARRANTY CONTAINS ARBITRATION AND CLASS ACTION WAIVER PROVISIONS (SEE BELOW IN SECTION 9). THIS LIMITED WARRANTY ALSO CONTAINS LIMITATIONS OF LIABILITY (SEE BELOW IN SECTION 8).

WE LIMIT THE DURATION AND REMEDIES OF ALL IMPLIED WARRANTIES, INCLUDING WITHOUT LIMITATION THE WARRANTIES OF MERCHANTABILITY AND FITNESS FOR A PARTICULAR PURPOSE TO THE DURATION OF THIS EXPRESS LIMITED WARRANTY (SEE SECTION 2).

SOME STATES AND JURISDICTIONS DO NOT ALLOW LIMITATIONS ON HOW LONG AN IMPLIED WARRANTY LASTS, SO THE ABOVE LIMITATION MAY NOT APPLY TO YOU.

OUR RESPONSIBILITY FOR DEFECTIVE GOODS IS LIMITED TO THE STORE CREDIT AS DESCRIBED BELOW IN THIS LIMITED WARRANTY STATEMENT.

[warranty information continues on following page]

1. WHO MAY USE THIS WARRANTY?

Lumber Liquidators, Inc. (“we,” “us,” and “our”) extends this limited warranty only to the consumer who originally purchased the product (“you”) and only for residential use. It does not extend to any subsequent owner or other transferee of the product. **THIS LIMITED WARRANTY IS NOT TRANSFERABLE. THE LIMITED WARRANTY EXTENDS ONLY TO THE ORIGINAL END-CONSUMER.** For purposes of this limited warranty, a “residential use” is a product installation at a single-family home, apartment unit, townhouse, or other place where people live and, notwithstanding the forgoing list, excludes: (a) multi-family housing common areas; (b) any real estate property that is used for business or commercial activities; (c) any location used in whole or in part for business or commercial purposes; and (d) any location where foot traffic exceeds normal, residential foot traffic. We have the sole right to make the determination of whether an application is a residential use or another kind of use. For purposes of such determination, we may need to visit the location that relates to the warranty claim for inspection and use. This limited warranty does not apply to light commercial or heavy commercial use.

2. WHAT IS THE PERIOD OF COVERAGE?

Subject to the requirements listed in Section 5 below, this limited warranty starts on the date of your purchase and lasts for the time period set forth in the chart below for your specific product (the “Warranty Period”):

| Product Identification | Warranty Duration |
|------------------------------------|-------------------|
| Porcelain (Impervious) | Lifetime |
| Ceramic (Non-vitreous to vitreous) | 1 Year |

If, for any reason, we repair or replace the product, the Warranty Period is not extended. We may change the availability and duration of this limited warranty at our discretion, but any changes will not be retroactive.

Where the Warranty Duration noted above provides for a “Lifetime” warranty, the duration of this limited warranty shall be the lifetime of the original purchaser so for as long as he or she owns the flooring.

3. WHAT DOES THIS WARRANTY COVER?

During the Warranty Period and subject to the complete terms of this limited warranty, this limited warranty covers the following product aspects from defects in materials and workmanship of the purchased product (the “product”):

- **Limited Finish Wear Warranty.** Finish wear from normal residential use conditions resulting in the wearing through the glaze, subject to the exclusions provided in Section 4 below.
- **Product Structure.** The product will be free of manufactured defects in materials and workmanship.
- **Light Fading.** The product will not fade due to sunlight or electrical light exposure under normal residential conditions of use.
- **Limited Waterproof Warranty.** . The structural integrity of the product will not be significantly diminished by exposure to water during the Warranty Period under normal residential use conditions. This limited warranty extends only to topical moisture and topical water exposure. Please note that this warranty relates only to the purchased product itself and does not warrant that your subfloor, residence, or any other items or properties will be safe from water damage because of the installation of this product.

- **Limited Pet Stain Warranty.** While the vomit, urine, and feces are still wet (and such wetness is not exceeding twenty-four hours), the product will resist staining and damage caused by the vomit, urine, and feces of domestic cats and dogs that occur during normal residential use, subject to timely attention under the Installation and Care Requirements (defined and discussed below). Please note that this warranty relates only to the purchased product itself and does not warrant that your subfloor, residence, or any other items or properties will be safe or resistant from these pet stains because of the installation of this product.
- **Delamination.** The product will not delaminate under normal residential use conditions.

4. WHAT DOES THIS WARRANTY NOT COVER?

This limited warranty does not cover any defects or damages due to: (a) failure to strictly follow the Installation and Care Requirements (defined and discussed below) regardless of the installer; (b) transportation; (c) storage; (d) improper use; (e) modifications; (f) unauthorized repair; or (g) external causes such as accidents, abuse, or other actions or events beyond our reasonable control. In addition, this limited warranty does not cover any defects or damages due to the following:

- **Excessive Moisture.** Non-structural damages caused by moisture (such as mildew and mold) are excluded. In addition, moisture intrusions from concrete hydrostatic pressure, flooding, or plumbing leaks, along with high levels of alkalinity, can affect surrounding structure, walls, subfloor, fixtures, furniture, underlayment, moldings, trims, subfloor heating elements, or anything that is not the product. Damage from such conditions, including to the floor and subfloor, is not covered under this limited warranty.
- **Moisture Protection.** This flooring should not be used to seal an existing floor from moisture. This flooring cannot prevent problems associated with, or caused by flooding, excessive moisture, existing moisture, or alkalis in the subfloor or conditions arising from hydrostatic pressure. To be abundantly clear, this limited warranty does not cover damage to surrounding structure, walls, subfloor, fixtures, furniture, underlayment, moldings, trims, subfloor heating elements, or anything that is not the product itself. This limited warranty does not cover damage resulting from mold and/or mildew growth due to prolonged exposure to moisture, all casualty events involving water coming in contact with your floor and failures normally covered by insurance, including, but not limited to, damages caused by flooding or standing water from leaky pipes, faucets, or household appliances.
- **Site and Environmental Conditions.** Defects or damages resulting from: site conditions (such as extreme heat or exposure to sand); indentations and scratches (caused by furniture, appliances, tools, grit, heels, toys, etc.); improper maintenance and accidents; misuse and abuse. These items are not covered under this limited warranty.
- **Tile Cracking.** Cracked tiles due to misuse, poor installation, subfloor movement or unevenness are not covered under this limited warranty.
- **Gloss Reduction.** Fading or loss of gloss (or glaze) is not finish wear and not a product defect covered under this limited warranty.
- **Other Finishes.** This limited warranty covers the factory-applied finish only. Applying another finish or sanding (such as in preparation for another finish) may damage the factory-applied finish and voids this limited warranty against finish wear.
- **Exterior Use.** This limited warranty does not cover exterior use of the product.
- **Visible Defects.** As discussed further below in Section 5.C., products installed with visible defects are not covered under this limited warranty. Accordingly, before installation, you and the installer should examine each product to ensure it is satisfactory.
- **Color and Shade Variations.** Shade variations are an inherent trait of porcelain and ceramic tiles. These variations should be expected. Inspect product before installation. Claims for color and shade variation will not be accepted after the product is installed.

- **Odd Lots.** An odd lot is flooring that is discounted because it did not pass our rigorous inspection process and is not covered by this limited warranty.
- **Third-Party Purchases.** This limited warranty does not cover any purchases other than those made directly from Lumber Liquidators in store, online, or by phone.
- **Radiant Heat.** This limited warranty does not cover any products installed over radiant heat that are not installed according to the radiant heat manufacturer guidelines or not installed in compliance with the Installation and Care Requirements.
- **Other Materials.** Grout mortar, crack isolation membranes, moisture barriers, and other materials used to install your porcelain or ceramic tiles are not covered by this limited warranty. Grouts, selling materials, and other tile installation products may have individual warranties. These additional materials are not covered by this limited warranty. Check with the retailer or manufacturer of these materials for the relevant warranties.
- **Outdoor Installation.** Outdoor and partial outdoor installations of the product void this limited warranty and are not covered.
- **Removal and Replacement.** This limited warranty does not cover the cost of the removal or replacement of Countertops, cabinets, built-in appliances or other fixtures, installed on top of your floor.
- **Improper Installation and Maintenance.** This limited warranty does not cover any dissatisfaction or damage due to improper installation or maintenance. This includes any damages caused by any installation (regardless of the source of the installation advice) that conflicts with the applicable industry installation standards and product installation instructions—for example, damage caused by sub-surface, sub-flooring and jobsite environmental deficiencies, improper transportation, acclimation and storage.
- **Cracking from Movement Joints.** This limited warranty does not cover incorrectly addressed movement joints (for example, perimeter joints, control joints, expansion joints) resulting in cracks.
- **Improperly Maintained Grout.** This limited warranty does not cover incorrectly maintained grout or damages resulting from incorrectly maintained grout.

5. HOW DO I MAINTAIN THIS WARRANTY DURING THE WARRANTY PERIOD?

To maintain this limited warranty during the Warranty Period, you are obligated to meet all of the following requirements for your use, installation, and maintenance of the product (the “Installation and Care Requirements”). The Installation and Care Requirements must be strictly followed for the limited warranty to remain valid and not be void.

- Follow the Pre-Installation Requirements.** Prior to installing a single board, tile, or product, you or the installer must determine that the job-site environment and the sub-surfaces (including subfloor substrates) meet or exceed applicable industry and product standards, including, without limitation, moisture testing and controls. The product installation instructions discuss these standards and are provided in full below. These requirements must be strictly followed.
- Comply with All Laws.** In your installation, maintenance, and use of the product you must comply with all laws and regulations, including, without limitation, all applicable environmental and building codes, regulations and laws.
- Inspect All Products for Visible Defects.** Products installed with visible defects are not covered under this limited warranty. Accordingly, before installation, you and the installer should examine each product to ensure it is satisfactory. If any products are unacceptable for any reason, it is up to you to determine to use them, hide them in areas like closets, trim off the imperfection, or not install them at all. You should plan on being present during your installation to ensure that all required procedures are completed and products with visible defects are not installed. It is important to inspect individual boards and tiles and to frequently step back to observe the “whole picture” before installation is completed. ***If quality issues are suspected before or during installation immediately contact the store where your floor was purchased or call us at 1-800-366-4204.***

- D. *Follow the Installation and Care Instructions.* It is your duty to make sure the installation requirements are strictly followed, including, without limitation, as they relate to the use of moisture barriers, installation tools such as nailers and trowels, and the evaluation of job site conditions and moisture testing. The product's installation and care manual(s) are provided in this document below, and those terms and provisions are part of this limited warranty.

6. WHAT ARE YOUR REMEDIES UNDER THIS WARRANTY?

With respect to any defective product during the Warranty Period, we will provide a Lumber Liquidators store credit in the amount of the purchase price paid for the defective portion of the flooring (excluding any installation costs and labor). A store credit is the sole remedy under this warranty and can be used for store product purchases only. Provided, however, we reserve the right, in our sole discretion, to repair or replace such product (or the defective part) free of charge in lieu of a store credit. We will also pay for shipping and handling fees to return the repaired or replacement product to you if we elect to repair or replace the defective product.

There is no guarantee that the same or a similar product to the original flooring will be available at the time a store credit is issued or redeemed.

We reserve the right to investigate, assess, and validate reported claims by, among other things, requesting samples from you for technical analysis and performing an inspection of the flooring and installation location.

7. HOW DO YOU OBTAIN WARRANTY SERVICE?

To file a warranty claim during the Warranty Period, you may:

- A. Visit the store where you purchased your floor;
- B. Call us at 1-800-366-4204; or
- C. Email via the "contact us" link at www.lflflooring.com

Claims must be submitted within the Warranty Period and within ninety (90) days of the date that the problem with the floor is first discovered. No warranty claim will be serviced without contacting us through one of the methods listed above and providing accurate and complete information in a timely manner.

8. WHAT ARE THE LIMITATIONS OF LIABILITY?

THE REMEDIES DESCRIBED ABOVE IN SECTION 6 ARE YOUR SOLE AND EXCLUSIVE REMEDIES AND OUR ENTIRE LIABILITY FOR ANY BREACH OF THIS LIMITED WARRANTY. NOTWITHSTANDING ANY OTHER PROVISION OR TERM, OUR LIABILITY SHALL UNDER NO CIRCUMSTANCES EXCEED THE ACTUAL AMOUNT PAID BY YOU FOR THE DEFECTIVE PRODUCT OR DEFECTIVE PORTION THEREOF.

UNDER NO CIRCUMSTANCES SHALL WE BE LIABLE FOR ANY CONSEQUENTIAL, INCIDENTAL, SPECIAL OR PUNITIVE DAMAGES OR LOSSES, WHETHER DIRECT OR INDIRECT. WITHOUT LIMITING THE FORGOING SENTENCE, LOSSES, DAMAGES OR EXPENSES RELATING TO ANYTHING OTHER THAN THE FLOOR ITSELF ARE NOT COVERED, INCLUDING, WITHOUT LIMITATION, MISSED TIME FROM WORK, HOTEL STAYS, STORAGE FEES, KENNEL COSTS FOR PETS, REMOVAL OF DEFECTIVE FLOORING, INSTALLATION OF REPLACEMENT FLOORING, OR REMOVAL OR REPLACEMENT OF ITEMS BUILT ON TOP OF ANY FLOORING (FOR EXAMPLE, COUNTERTOPS, CABINETS, BUILT-IN APPLIANCES).

SOME STATES AND JURISDICTIONS DO NOT ALLOW THE EXCLUSION OR LIMITATION OF INCIDENTAL OR CONSEQUENTIAL DAMAGES, SO THE ABOVE LIMITATION OR EXCLUSION MAY NOT APPLY TO YOU.

9. TERMS OF DISPUTE RESOLUTION

NO JOINT OR CLASS ACTIONS: Neither you nor Lumber Liquidators shall be entitled to join or consolidate claims in arbitration by or against other customers of Lumber Liquidators with respect to other accounts, bring mass, class action, or consolidated claims in arbitration or a court of competent jurisdiction, or arbitrate or litigate any claim as a representative or individual of a class

or in a private attorney general capacity. The arbitrator may not consolidate more than one person's claims and may not otherwise preside over any form of a representative or class proceeding.

ARBITRATION: The following informal dispute resolution procedure is available to you if you believe that we have not performed our obligations under this limited warranty. You must use this informal procedure before pursuing any legal remedy in the courts.

Lumber Liquidators and you agree to attempt to resolve any disputes amicably. If, after thirty (30) days we are unable to do so, then you and Lumber Liquidators each agree that any claim or controversy of any sort relating to our agreement, the Products or these limited warranty terms shall be determined by arbitration in the nearest U.S. city to the Lumber Liquidators store where you purchased the products, before one arbitrator. At the option of the first to commence an arbitration, the arbitration shall be administered either by JAMS pursuant to its Streamlined Arbitration Rules and Procedures, or by the American Arbitration Association pursuant to its Commercial Arbitration Rules. The arbitrator shall have no power to add to, delete from or modify these limited warranty terms. Each of us shall have the right to conduct discovery to which we would be entitled had the dispute been resolved in a state court of general jurisdiction in the state of the Lumber Liquidators store where you purchased the products. Judgment on the arbitrator's award may be entered in any court having jurisdiction. This clause shall not preclude either party from seeking provisional remedies in aid of arbitration from a court of appropriate jurisdiction. The arbitrator may, as part of the award, allocate all or part of the costs of the arbitration, including the fees of the arbitrator and the reasonable attorneys' fees of the prevailing party. The arbitrator shall only have the authority to resolve individual disputes between you and Lumber Liquidators. Notwithstanding the foregoing, in addition to our rights set forth above, we may initiate proceedings directly in the appropriate court located in the U.S. city nearest the Lumber Liquidators store where you purchased the products in connection with any claim to collect amounts due and owing by you.

10. NO OTHER TERMS

SAMPLES, DESCRIPTIONS, AND OTHER INFORMATION CONCERNING THE PRODUCT CONTAINED IN CATALOGS, ADVERTISEMENTS, OR OTHER PROMOTIONAL MATERIAL OR STATEMENTS MADE BY SALES REPRESENTATIVES OR DISTRIBUTORS ARE FOR GENERAL INFORMATIONAL PURPOSES ONLY AND ARE NOT BINDING UPON LUMBER LIQUIDATORS. NO SALES REPRESENTATIVES, STORE MANAGERS, ACCOUNT REPRESENTATIVES, OR DISTRIBUTORS SHALL HAVE ANY AUTHORITY WHATSOEVER TO ESTABLISH, EXPAND OR OTHERWISE MODIFY LUMBER LIQUIDATORS' WARRANTIES. THE TERMS OF THIS LIMITED WARRANTY DOCUMENT MAY NOT BE AMENDED EXCEPT THROUGH A WRITTEN AGREEMENT TITLED "AMENDMENT TO LIMITED WARRANTY" AND SIGNED BY AN AUTHORIZED OFFICER OF LUMBER LIQUIDATORS, PROVIDED, HOWEVER, THAT LUMBER LIQUIDATORS MAY GENERALLY MODIFY, CANCEL, UPDATE, OR OTHERWISE CHANGE ITS PROSPECTIVE WARRANTIES FOR FUTURE SALES AT ANY TIME AND FOR ANY REASON.

11. OTHER PROVISIONS

The section headings provided in this limited warranty are for convenience and informational reference only and shall not affect the interpretation or construction of this limited warranty.

THE PROVISIONS OF THIS LIMITED WARRANTY ARE DEEMED TO BE SEVERABLE AND THE INVALIDITY OR UNENFORCEABILITY OF ONE PROVISION SHALL NOT AFFECT THE VALIDITY OR ENFORCEABILITY OF ANY OTHER PROVISION.

12. ADDRESS FOR LUMBER LIQUIDATORS

Lumber Liquidators, Inc. is located at 4901 Bakers Mill Lane, Richmond, VA 23230.

[HOME * INSTALL * CARE](#)

Save time & avoid frustration! Please read these entire instructions before starting your installation, and A.I.M. for success!

AIM

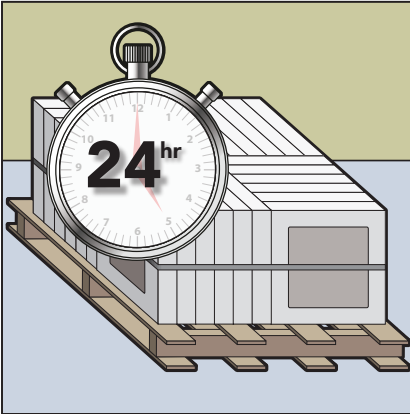

Acclimate Completely
Generally, acclimation is not required for Ceramic or Natural Stone tile. However, tile and stone should be within 20° F of the floor to which it will be installed on for 24 hours. Don't install cold tile.

AIM



Install Correctly
Take time to review Lumber Liquidators' installation guidelines and follow the National Wood Flooring Association Guidelines to ensure that your installation goes well from beginning to end.

AIM



Maintain Environment
Temperatures can be maintained at your personal interior and exterior comfort levels for the life of the floor.



Need Help? To obtain installation assistance or product information concerning this flooring, contact the store of original purchase, or call the Lumber Liquidators customer care at 800-366-4204.



WARNING! DO NOT SAND, DRY SWEEP, DRY SCRAPE, DRILL, SAW, BEADBLAST OR MECHANICALLY CHIP OR PULVERIZE EXISTING RESILIENT FLOORING, BACKING, LINING FELT, ASPHALTIC "CUTBACK" ADHESIVES OR OTHER ADHESIVES.

These products may contain asbestos fibers and/or crystalline silica. Avoid creating dust. Inhalation of such dust is a cancer and respiratory tract hazard. Smoking by individuals exposed to asbestos fibers greatly increases the risk of serious bodily harm. Unless positively certain that the product to be removed is a non-asbestos containing material, you must presume it contains asbestos. Regulations may require that the material be tested to determine asbestos content. See current edition of the Resilient Floor Covering Institute (RFCI) publication, "Recommended Work Practices for Removal of Resilient Floor Coverings" for detailed information and instructions on removing all resilient covering structures. For current information, go to www.rfci.com.



LEAD WARNING: Some paints and finishes in homes built before 1978 may contain lead. Exposure to excessive amounts of lead dust presents a health hazard. Prior to removing or sanding, comply with all applicable federal, state, and local laws, and reference the publication "Lead-Based Paint: Guidelines for Hazard Identification and Abatement in Public and Indian Housing" available from the United States Department of Housing and Urban Development regarding (1) appropriate methods for identifying lead-based paint and removing such paint; and (2) any licensing, certification, and training requirements for persons performing lead abatement work.



MOLD AND MILDEW WARNING: Prior to removing an existing resilient floor or when installing a new floor, if there are visible indications of mold or mildew or the presence of a strong musty odor in the installation area, the source of the problem should be identified and corrected before proceeding with the flooring work. Excessive moisture in the subfloor could promote mold, mildew, and other moisture related issues like the trapping of moisture emissions under the flooring, which may contribute to an unhealthy indoor environment. Mold has the potential to cause health problems and may produce allergens, irritants, and in some cases, potentially toxic substances. Before installing the new resilient flooring, ensure the underlayment and/or subfloor is allowed to thoroughly dry and that any residual effect of excessive moisture, mold, or structural damage has been corrected. Remediation measures may require structural repairs such as replacing the contaminated underlayment and/or subfloor, cleanup measures using appropriate protection and biocide, or hiring a professional mold and mildew remediation contractor. Consult EPA mold guidelines on EPA's website at <https://www.epa.gov/mold>

RECOMMENDED USE:

Residential and light / heavy commercial interior applications * see warranty for more details. Product selected should comply with Tile Council of North America, Inc. Handbook for Ceramic, Glass, and Stone Tile Installation (TCNA) and American National Standard Specifications for the installation of Ceramic Tile (ANSI).

GRADE: On, above and below grade.

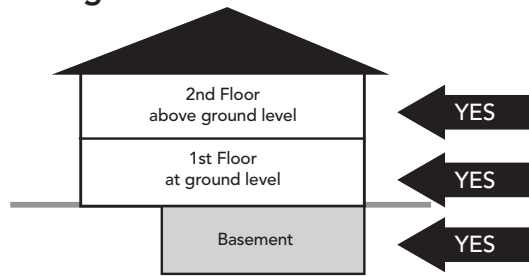

JOBSITE CONDITIONS:

Jobsite conditions can have a serious impact on the success or failure of a tile installation.

- Ensure that exterior doors and appliances have sufficient clearance to accommodate the new flooring.
- Do not undercut metal door jambs before first confirming it doesn't violate local building and fire codes
- Close spaces in which tile is being set, to traffic and other work until tile is firmly set for a minimum of 24 hours unless setting material manufacturers states differently.
- Do not walk nor work on newly tiled floors that has not cured for at least 24 hours without using knee board or equivalent protection of the tiles surface
- Keep traffic off the tile until completely set. Review setting material manufacturers Technical Data Sheets
- Do not apply setting material to surfaces that are outside of the manufacturers recommended environmental conditions e.g. frost.

USER / OWNER / INSTALLER RESPONSIBILITIES:

- Install in good lighting.
- Check that all material is the correct color/pattern and that all cartons are from same batch and lot number. During installation mix and install tiles from several different cartons to ensure best overall color/shade appearance.
- Every effort is made to inspect materials during manufacturing and handling. It is the installer or end-user responsibility to inspect all material for defects and confirm that the correct color/pattern is received prior to installation.
- Do not install material with visible defects. Installation implies acceptance of materials.
- Create a mockup, sufficient in size, so you can view a sample of the actual installation which includes items such as tile color/variation, grout joint size/color and gauge the variation from tile to tile which ensures that the final installation meets your expectations.
- Retain a box label and keep on file with your receipt for future reference.
- If quality issues are suspected stop the installation and call your local store or CUSTOMER CARE at 800-366-4204.

STORAGE:

Deliver and store packaged material in original unopened containers with labels intact until the time of use. To prevent breakage tile must be transported on its edge not flat. Store and handle materials in a manner to prevent damage or contamination by water, freezing or foreign matter.

ACCLIMATION:

Generally, acclimation is not required for Ceramic tile or Natural stone tile.

TEMPERATURE:

Many products used in tile installations require that the temperature be maintained within a specific range and duration. Temperature can affect the cure / drying time of setting and finishing materials. Tile and stone should be within 20°F of the substrate it will be installed on.

Follow the manufacturer's guidelines / Technical Data Sheets to ensure a long-lasting installation.

RELATIVE HUMIDITY:

Relative Humidity can affect the cure / drying time of setting and finishing materials.

Follow the manufacturer's guidelines / Technical Data Sheets to ensure a long-lasting installation.

CUTTING ALLOWANCE:

A typical project cutting waste allowance for straight lay would be between 5 – 10% and on a diagonal between 15 – 20%.

Large format tile should be planned out carefully, and an exact count of tile required determined. Additional tiles should then be added to the total for cutting errors / breakage.

Cutting Waste may be higher based on room layout, and product description.

Tip: Keep an extra box for future repairs.

ESTIMATING:

There are two basic methods to estimate tile:

Square Foot (length x width)

To determine the square footage of a square or rectangular room, simply multiply the (length x width) for the total square feet (sq ft). For example, a 12x12 room area has 144 (sq ft). Round- up to the quantity per unit sold. For irregularly shaped areas like closets, and counters, multiply the length and width of the extra space separately, then add this number to the square footage of the main part of the room.

Note the size (length and width) of your tiles. The size of the tiles will be on the product packaging, or invoice.

Individual Tile Count

For accurate tile count ,the process begins on paper. Make a drawing to scale of the area that is going to receive tile, note doorways, pipes, features e.g. fireplaces. Once complete the layout and the count of the tile can be determined. A simple layout and count is shown below.

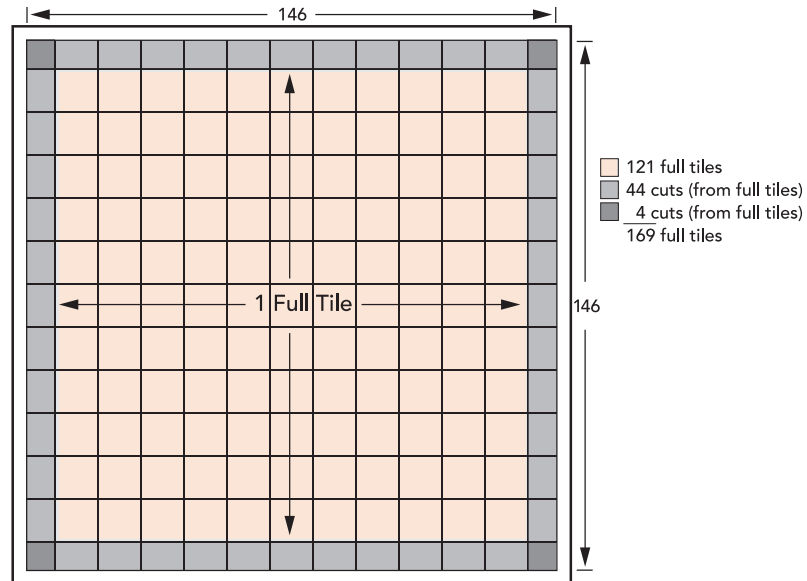

There are many aspects to a room that can influence the layout of the tile, and careful planning is essential for an aesthetically pleasing installation.

SURFACE PREPARATION:

Follow applicable ANSI and TCNA installation standards.

Generally:

Surfaces shall be structurally sound, clean, dry and free of oily or waxy films and all foreign matter.

TCNA recommends roughening or scarifying glazed tile substrates. If installing over existing tiles, verify that all of the tiles are well secured to the substrate to which they are installed.

For thin and medium set methods, concrete shall have a steel trowel, fine broom or wood float finish or mechanically scarified (Caution should be exercised if the concrete has been power troweled to a hard finish).

NOTE: It is the end users / installers responsibility to determine the condition and suitability of all surfaces before application.

DEFLECTION:

Tile and stone are very rigid materials and do not accommodate movement well. They may potentially break or delaminate from the substrate if it bends excessively under load.

No movement should be visible. Every installation needs to have a firm, stable subfloor, for tile or stone to be installed successfully.

Deflection is one area that needs to be considered seriously.

The Tile Council of North America states in the TCNA Handbook for Ceramic, Glass, Stone and Tile Installation that tile installation systems, whether wood framed or concrete, shall be in conformance with the International Residential Code (IRC) for residential applications, the International Building Code (IBC) for commercial applications, or applicable building codes. Maximum allowable floor member live load and concentrated load deflection shall not exceed $L/360$ (for ceramic tile) and $L/20$ (for Stone), where "L" is the clear span length of the supporting member per applicable building code.

Maximum deflection limits are set by building codes. They are expressed as a fraction; clear span in inches (L) over a given number. For example: a floor joist appropriately selected to span 10 feet with an $L/360$ limit will deflect no more than $120"/360 = 1/3$ inches under maximum design loads.

Examples of code-prescribed deflection limits and live load values are:

- Living room floors $L/360$ & 40 psf
- Bedrooms and habitable attic floors $L/360$ & 30 psf

Generally, natural stone tile requires additional substrate preparation. One method is to use of two layers of structural wood panels and then a cementitious backer unit applied as the substrate to adhere the tile too.

CONCRETE SLAB FLATNESS VARIATION:

Standard Tile

ANSI (American National Standards Institute) specification for tiles with all edges shorter than 15", recommends the substrates maximum allowable variation $\frac{1}{4}$ " in 10' from the required plane, with no more than 1/16th variation in 12" when measured from the high points of the surfaces.

Large Format Tile

When installing large format tile the flatness of the substrate is paramount to the success of the installation.

ANSI (American National Standards Institute) specification for tiles with a least one edge 15" in length, recommends the substrates maximum allowable variation is 1/8th in 10' from the required plane, with no more than 1/16th variation in 24" when measured from the high points in the surface. These variation seem minor, but large format tile will exaggerate slab variances beyond the recommended levels given above, resulting in an unsatisfactory installation.

Diamond Grinding and Self-leveling compounds are recommended for substrates that exceed the ANSI standards. Do not use tile setting materials to flatten substrates, use applicable Portland based leveling or patching compounds.

CRACK ISOLATION MEMBRANE:

Concrete substrates often crack during the drying and curing process or due to minor movement. In plane cracks can be isolated, but cracks that are caused by vertical deflection (one side of crack higher than the other) cannot be addressed with a crack isolation membrane.

If tile or stone is installed over cracks that are not addressed, the crack may still be active after installation and cause the tile to crack (Reflective cracking) resulting in expensive repairs.

The internal make-up of a membrane is such that movement in the concrete is not directly transferred to the tile. Although the membrane is bonded to the concrete and the tile to it, the membrane stretches where needed to prevent or reduce force transference.

If the slab exhibits in plane cracks, a crack isolation membrane should be used. This can be partial, to deal with existing cracks or full cover to future protect against in plane cracks. Crack isolation membranes are covered in detail in the TCNA (Tile Council of North America) Handbook.

Soft joints (Flexible grout) allow the tile to "flex" with movement in the crack, giving additional protection. (see Movement Joints / Control joints for additional uses of Crack Isolation Membranes).

F113-16 STONE

- On- or Above-ground Concrete
- Crack Isolation Membrane (Partial Coverage)
- Natural Stone Tile

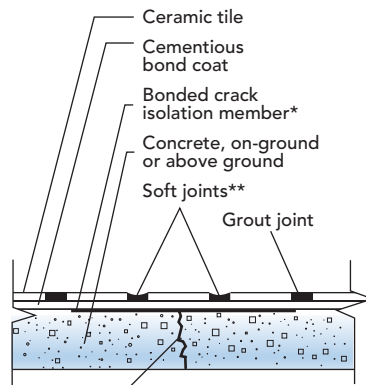

*Consult manufacturer for membrane width

**One or two soft joints may be required (consult manufacturer)

F113-16

- On- or Above-ground Concrete
- Crack Isolation Membrane (Full Coverage)
- Ceramic Tile

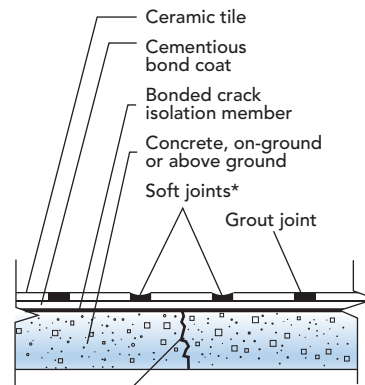

*One or two soft joints may be required (consult manufacturer)

Examples; Bostik GoldPlus (Full and Partial Coverage) and Fiber Fusion Anti-Fracture Crack Isolation Membrane (Full Coverage).

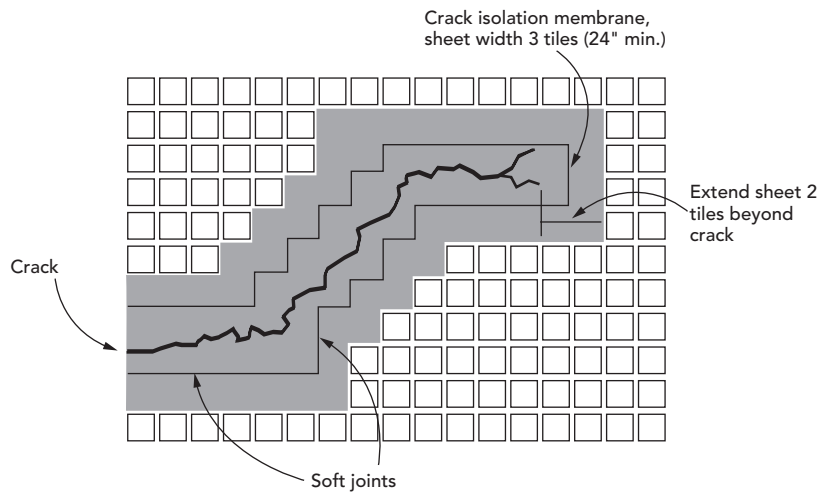

MOVEMENT JOINTS – PERIMETER, CONTROL , EXPANSION AND LIPPAGE:

Movement joints are required to account for variations in expansion and contraction between different materials. E.g. concrete and tile. Failure to address movement joints can result in tenting, cracking and broken tiles.

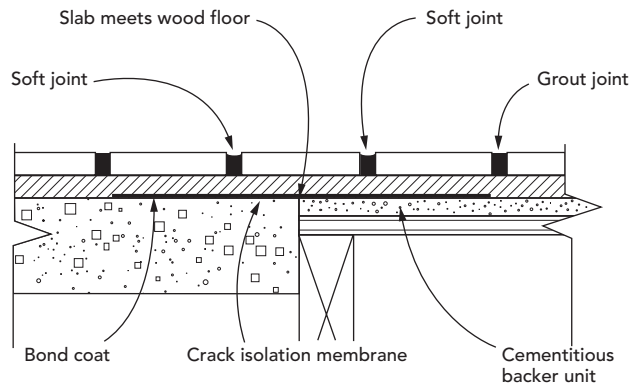

Perimeter Movement

Perimeter Movement joints (1/4" min) are required where tile / stonework abuts against surfaces that will stop movement, e.g. walls, curbs, columns, pipes.

EJ171G-16

• Perimeter Joint

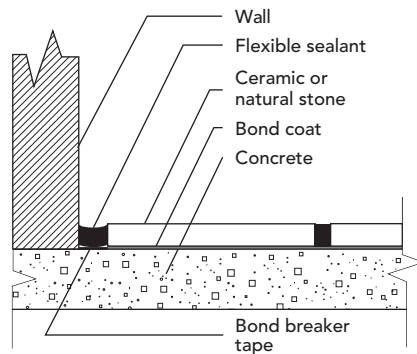

Control

Control joints are planned cracks, which allow for movement caused by temperature changes / drying shrinkage.

In homes these are often placed where walls will hide them. But large rooms may have control joints every 20' – 25' or if in direct sunlight 8' – 12'

Note: exterior installation control joints are set at 8' – 12'.

Crack Isolation membranes may be used (per manufacturer instructions / Technical Data Sheet) to allow tile installation over them as long as vertical deflection is not an issue.

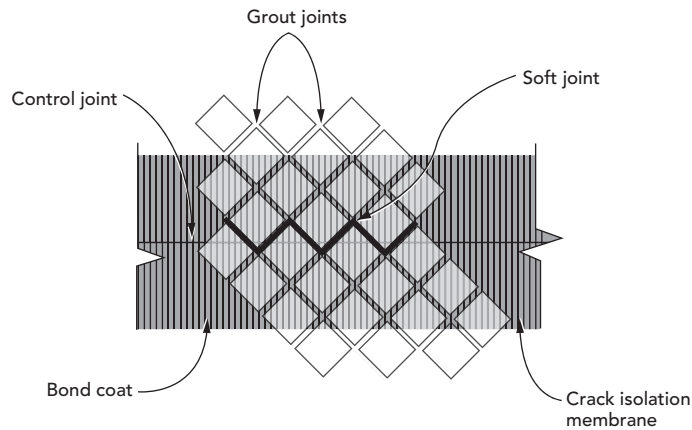

It is a frequent misconception that anti-fracture membranes allow you to eliminate movement joints - they do not. There always must be soft joints in the tilework to allow for expansion and contraction.

Typically, the soft joints (Sanded caulk for example) in the tile installed over an anti-fracture membrane must be placed near the joints in the concrete but not necessarily directly in line with the control joints.

Expansion

Expansion joints are placed where adjoining parts of a structure need to move and expansion exceeds contraction. These joints must be honored and reflect through the tile. They are often used on large projects.

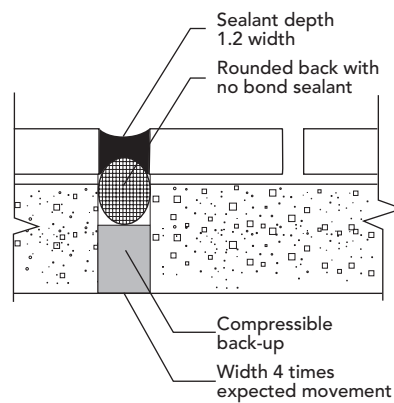

Large areas of tile also need expansion or control joints every 20' – 25' or if in direct sunlight 8' – 12'.

Note: exterior installation control joints are set at 8' – 12'.

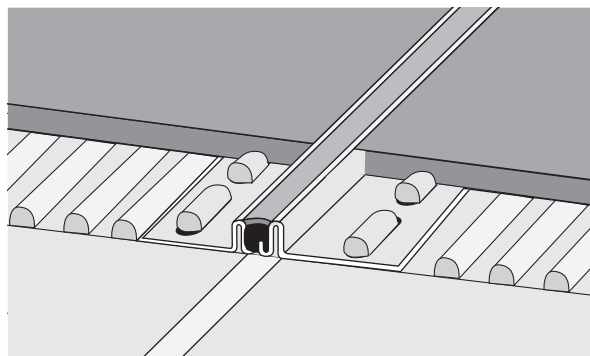

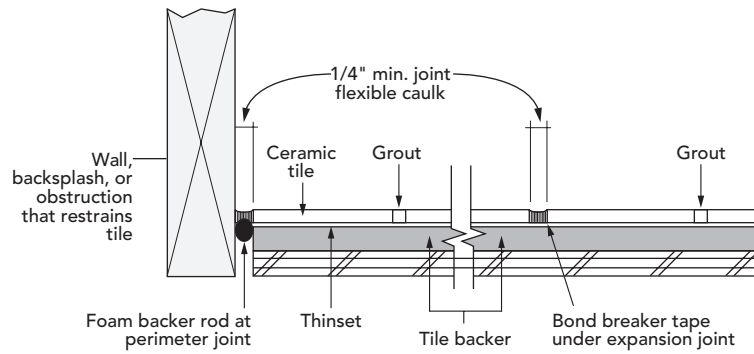

There are many solutions for addressing expansion joints, above are just a couple of examples. Your project may require a different solution.

Lippage

Lippage occurs when one side of a tile is higher than the adjacent tile, giving the finish an uneven appearance. Tight joints, lack of edge chamfer, high gloss and polish finishes will all extenuate lippage.

Layout, surface preparation, larger grout joints and specialist lippage / tile spacer systems e.g. Wedge Lippage System Spacers, can all help reduce the appearance of lippage. Lippage is inherent in all ceramic tile installation and needs to be managed using the above methods.

Natural stone tile is limited to 1/32" between adjacent units.

The TCNA Handbook highlights allowable lippage for ceramic tiles:

| Tile Type (in.) | Tile Size (in.) | Joint Width Lippage (in.) | Allowable |
|-----------------------------------|-----------------|---------------------------|-----------|
| Pressed Floor and Porcelain Tiles | All | 1/16 to less than 1/4 | 1/32 |
| Pressed Floor Porcelain Tiles | All | 1/4 greater | 1/16 |

USEFUL TOOLS:

Tape Measure, straightedge, spirit level, square (combination or carpenter's) chalk line, pencil or felt tip pen, Flat trowel, margin trowel, snap cutter and biters, tile spacers / lippage spacers, wet saw, hole saw, grout float (specific to grout), buckets, sponges, safety glasses gloves

ADDITIONAL NOTES:

When moving furniture and heavy equipment, use luan board, plywood, or other similar covering to protect the floor.

Moisture intrusions from concrete via hydrostatic pressure, flooding, or plumbing leaks, along with high levels of alkalinity, can affect tile over time.

Each project is unique and different. Installation advice or recommendations are given as a courtesy and not intended to take the place of an installer's visual inspection, expertise, knowledge of TCNA, ANSI and local building codes, or informed judgment, which will override any advice or recommendations given in the Installation Guidelines. The end user / contractor on-site is ultimately responsible for ensuring that selected products are appropriate for local conditions and / or the final use of the product.

Installation of Ceramic Tile / Natural Stone Tile

STEP 1. Base Board / Quarter Round / Door Casings / Jambs:

Aesthetically removal of quarter round baseboard and installation of new after the tiles is installed, undercutting door casings and jambs to allow the tile to slide under the doorjamb is a much more pleasing finish than butting up to the baseboards or cutting around a door casing. Do not undercut metal doorjambs before first confirming that it is not against local building codes.

A 1/4" perimeter gap must always be left to allow for expansion and contraction of the tile / stone. Abutting the tile / stone or grouting up to the baseboard may result in cracking / crumbling of the tile or grout over time.

If cutting door casings and jambs with a jamb saw to allow the flooring to slide under the doorjamb. If a baseboard is still in place, extend the undercut about 1" beyond the door frame casing. To find the height to cut the jamb, take a tile and lay next to door frame set jamb saw to correct depth or lay manual saw on top of the tile.

Always leave 1/16" clearance under the door jamb / casing for the floor to be able to float freely without vertical restriction.

Adjust as required.

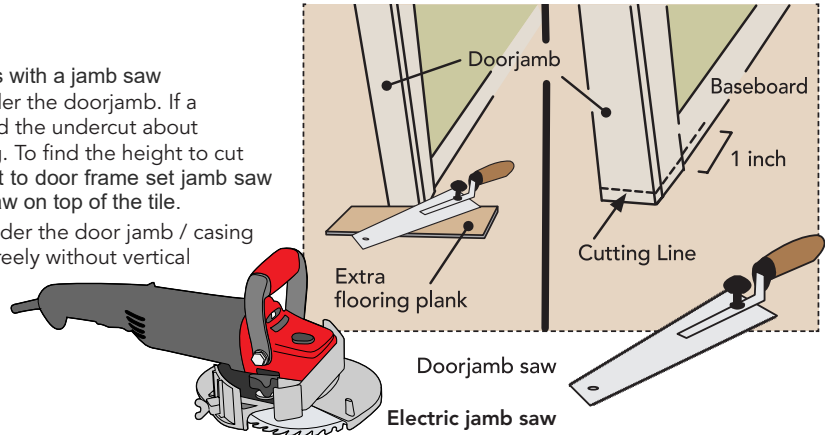

Pattern Ideas depending on tile selected



STEP 2. Basic Room Layout:

Take the time to figure out the best way to arrange the individual tiles. In most room areas, square and rectangular tiles will fit together in a simple grid pattern. First, establish a series of layout lines to serve as a placement guide by finding the midpoint of each wall and drawing a line across to the opposing wall. From there, you can begin dry-fitting the tiles around the room's center point, working your way outward in manageable sections to avoid uneven spacing.

For a balanced layout determine the center of the room.

Using a 12 x 12 room area as an example the midpoint or half is 6 feet.

Mark on the floor the midpoint of each long wall. Divide the total length of the walls in half, then mark it on the floor.

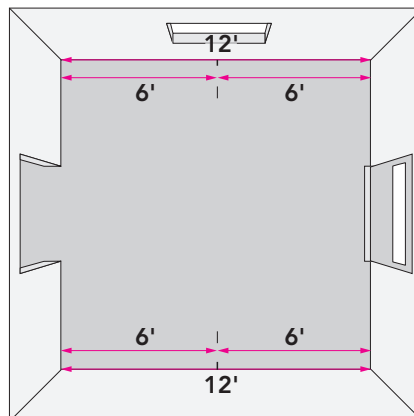

Connect the midpoint marks using a chalk line to find the room's center.

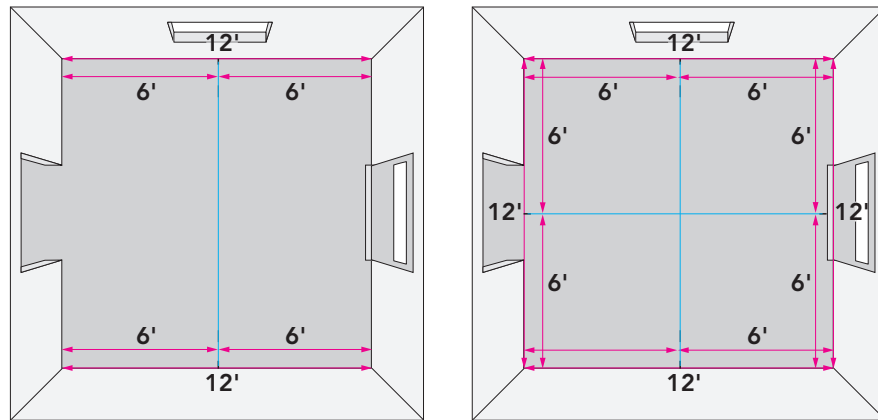

Repeat the process on the room's shorter walls.

Measure the length of the shorter walls, then mark the midpoint of each. Draw a line connecting the opposing midpoints through the center of the room. This line will intersect the first line, indicating the exact center of the room. When tiling adjoining rooms, ensure your working lines run from one room to the next. Make sure the working line is positioned in the center of both rooms.

Arrange the tiles outward from the center of the room.

Dry-fit 8 tiles where the wall lines intersect. Beginning at the center of the room rather than at the walls ensures a more symmetrical appearance and will prevent you from ending up with gaps or narrow tiles around the outer perimeter of the room.

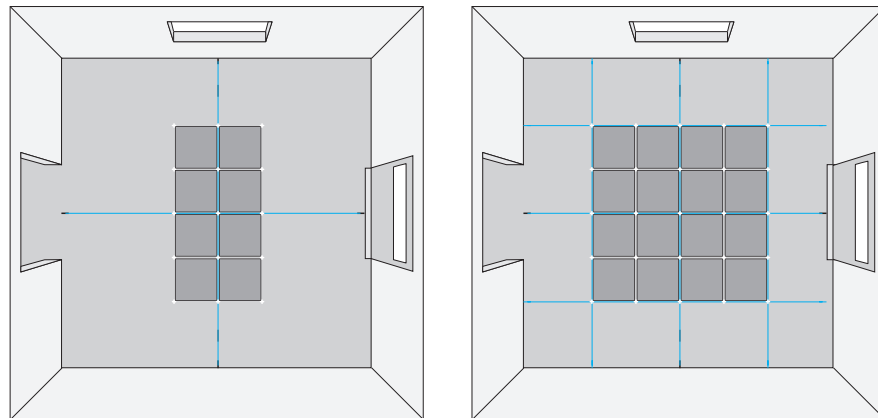

Lay the tile in 2-3 ft sections.

The optimum size of each section will vary based on the dimensions of the tile. When working with 12 in. square tiles, the section groupings might be comprised of 2 - 3 tiles in each direction (for a total of 4 - 6 tiles per section) For a visual aid to help keep track of the sections, snap a series of chalk lines to clearly mark where each next group of tiles should go. Dry-fitting the tile in sections usually results in straighter, more precise grout lines.

Work towards the walls.

When satisfied with the dry-fitting and layout of the tiles begin setting the tiles in the cement mortar starting from the center lines working a section in a straight line until you reach the wall. Then, return to the center and work your way toward the opposite wall.

Cutting the last tiles at the walls and fixtures

A power wet saw and "score and snap" tile cutter can be used to cut tiles.

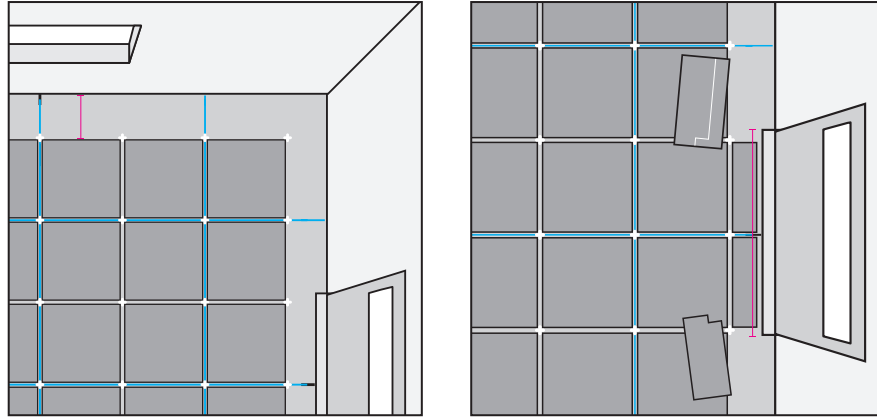

For Irregular-Shaped Rooms

To maintain squareness and true (90 degree) right angles of rooms, especially irregular-shaped rooms use the 3ft - 4ft - 5ft method. For larger rooms use a multiple of the 3 - 4 - 5 rule such as; 6 - 8 - 10 or 9 - 12 - 15 and so on. Any triangle with sides of 3, 4 and 5 feet will have a (90 degree) angle opposite the 5 - foot side. Measure and mark 4 feet outward from the primary centerline of the longest wall. Then make a second mark 3 feet from the center of the secondary line. Next Stretch a tape measure between the 3 ft. mark and the 4 ft. mark. The distance between the 2 marks should be exactly 5 ft. a true (90 degree) right angel. If the measurement is less than 5 feet, the angle is less than (<90 degrees) and needs to be adjusted. If it is more than 5 feet, the angle more than (>90 degrees) and needs to be adjusted.

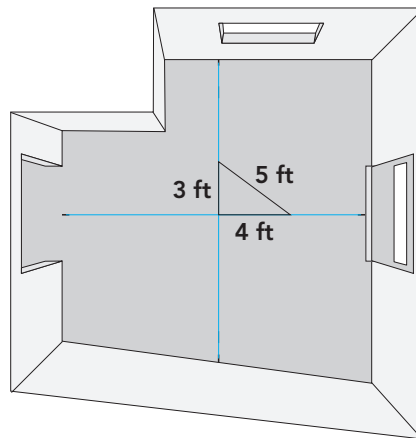

Basic L Shape

L shaped floors are simply two square / rectangular areas placed together. The layout is simply to project the reference lines from the longest wall in each section and positioned such that one falls in each leg of the L. See below:

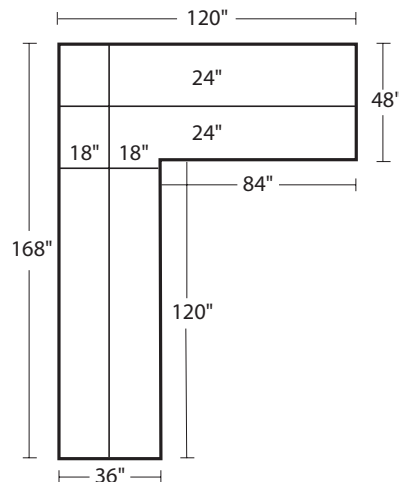

Multiple Rooms

For multiple rooms the problem becomes a little more complex. Each room has to connect with the others. The initial line (Line 1 and 2) connect the rooms. Additional layout lines can then be plotted in each room. See below:

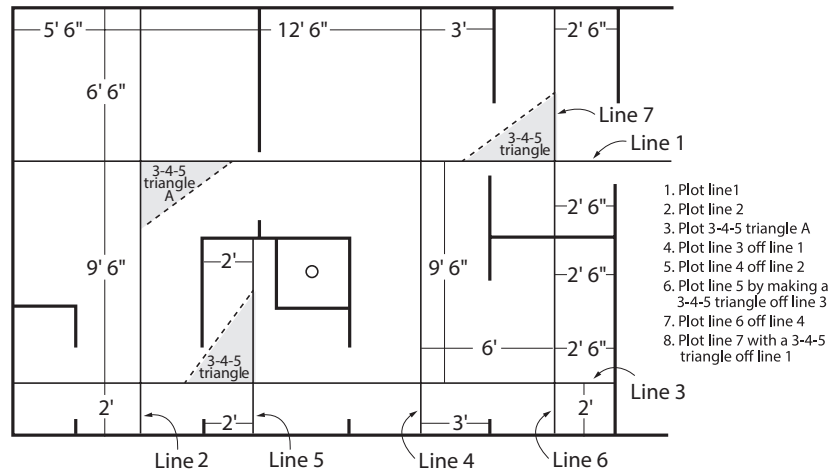

Step 3. Choose the installation method:

There are many options for installing tile / stone concrete depending on the application / substrate. They are covered in detail the Tile Council or North America's (TCNA) Handbook.

Below are some of the more common installation options with the TCNA reference code.

Interiors Floors over Concrete

F113-16 and F113A-16

Recommended uses

For slab-on-ground construction where no bending stresses occur and thin-bed method is preferred.

For above ground structural slabs and other floors subject to movement and/or deflection where thin-bed installation of Ceramic Tile or Natural Stone Tile is desired.

F113-16 STONE

- On-ground Concrete
- Natural Stone Tile

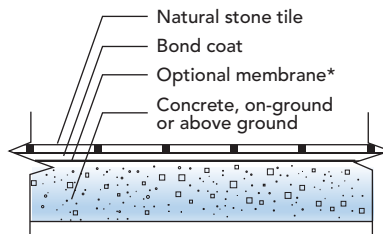

*Use of a membrane is optional. See membrane options.

F113-16

- On-ground Concrete
- Ceramic Tile

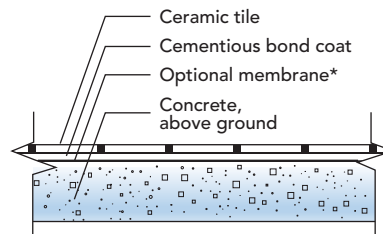

*Use of a membrane is optional. See membrane options.

On and above ground concrete with Cementitious Self-Leveling Underlayment

F205-16 and F205A-16

On-Ground concrete and above ground concrete
 Cementitious Self-Leveling Underlayment
 Ceramic Tile or Natural Stone Tile

Recommended Uses

For slab on ground and above ground and other floors subject to movement / deflection and flatness is critical e.g. natural stone tile of large format tile (any edge longer than 15").

F205-16 STONE

- On-ground Concrete
- Cementitious Self-leveling Underlayment
- Ceramic Tile, Natural Stone Tile

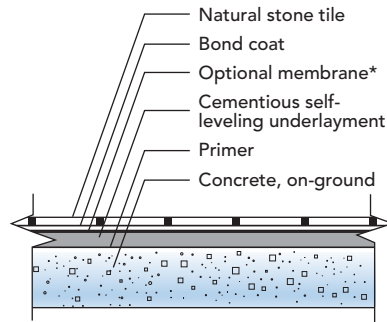

*Use of a membrane is optional. See membrane options.

F205A-16 STONE

- Above-ground Concrete
- Cementitious Self-leveling Underlayment
- Ceramic Tile, Natural Stone Tile

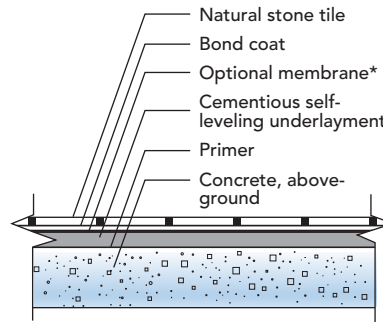

*Use of a membrane is optional. See membrane options.

Radiant Heat Electric and Hydronic Tubing

Electric Radiant Heat System

RH115-16 and RH115A-16

On-Ground concrete and above ground concrete
 Electric Radiant Heat System Encapsulated in Portland Cement Mortar
 Ceramic Tile or Natural Stone Tile

Recommended Use

For slab on- ground where no bending stresses occur and electrical radiant in- floor heat is desired.
 For slab above ground structural slabs, where electrical radiant in floor heat is desired.

RH115-16

- On-ground Concrete
- Electric Radiant Heat System Encapsulated in Portland Cement Mortar
- Ceramic Tile, Natural Stone Tile

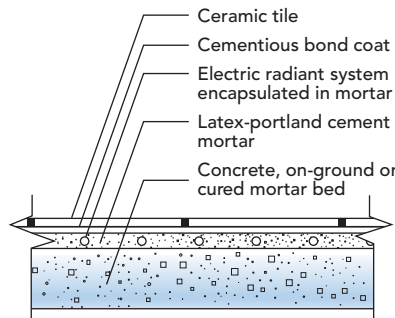

Use of a membrane is optional. See membrane options.

RH115A-16

- On-ground Concrete
- Electric Radiant Heat System Encapsulated in Portland Cement Mortar
- Ceramic Tile, Natural Stone Tile

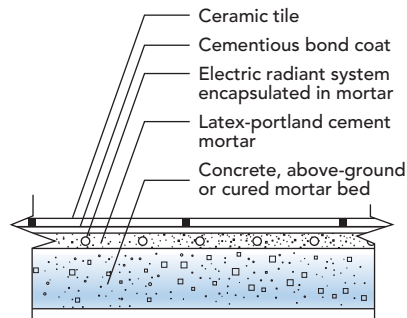

Use of a membrane is optional. See membrane options.

Hydronic Tubing

There are a number of Hydronic Tubing installation methods which include application over concrete, gypsum and wood substrates.

Examples are given below.

RH110-16 and RH110A-16

On Ground and Above Ground Concrete encapsulating Hydronic Tubing

Ceramic Tile or Natural Stone Tile

RH110-16

- On-ground Concrete Encapsulating Hydronic Tubing
- Ceramic Tile, Natural Stone Tile

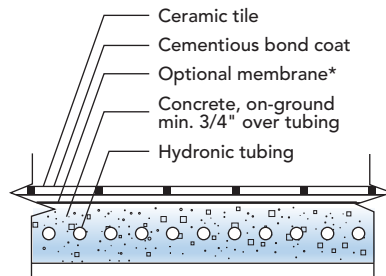

*Use of a membrane is optional. See membrane options.

RH110A-16

- Above-ground Concrete Encapsulating Hydronic Tubing
- Ceramic Tile, Natural Stone Tile

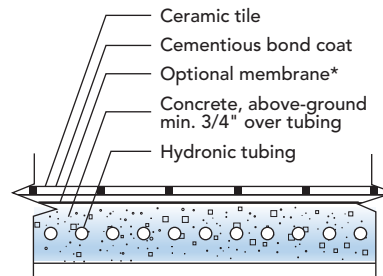

*Use of a membrane is optional. See membrane options.

Recommended Uses

For slab on ground construction where no bending stresses occur, thin-bed installation of Ceramic tile or natural stone tile is desired and Hydronic Tubing is encapsulated within the slab

For slab above - ground structural slabs, where thin-bed installation of Ceramic tile or natural stone tile is desired and Hydronic Tubing is encapsulated within the slab.

RH111-16

- On-ground Concrete
- Poured Gypsum Underlayment
- Encapsulating Hydronic Tubing
- Bonded Membrane
- Ceramic Tile, Natural Stone Tile

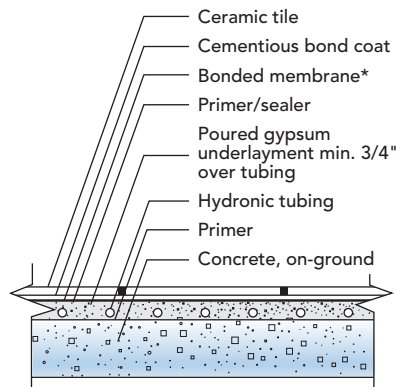

*Use of a membrane is required. See membrane options.

RH111-16 STONE

- On-ground Concrete
- Poured Gypsum Underlayment
- Encapsulating Hydronic Tubing
- Bonded Membrane
- Ceramic Tile, Natural Stone Tile

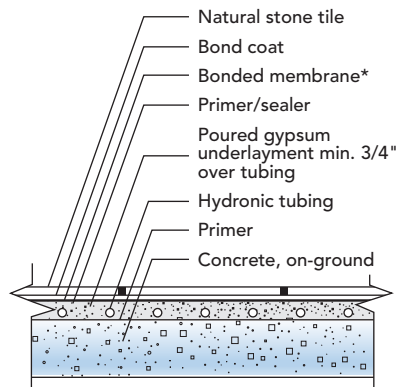

*Use of a membrane is required. See membrane options.

Recommended Uses

For slab on ground construction where no bending stresses occur and with poured gypsum underlayment encapsulating hydronic tubing.

RH111A-16

- Above-ground Concrete
- Poured Gypsum Underlayment
- Encapsulating Hydronic Tubing
- Bonded Membrane
- Ceramic Tile, Natural Stone Tile

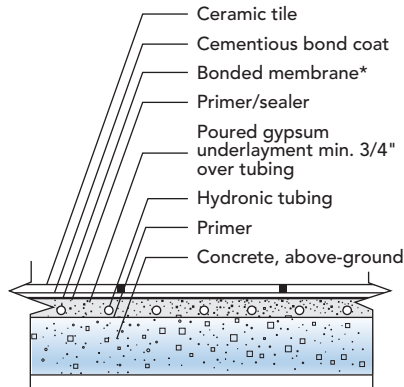

*Use of a membrane is required.
See membrane options.

RH111A-16 STONE

- Above-ground Concrete
- Poured Gypsum Underlayment
- Encapsulating Hydronic Tubing
- Bonded Membrane
- Ceramic Tile, Natural Stone Tile

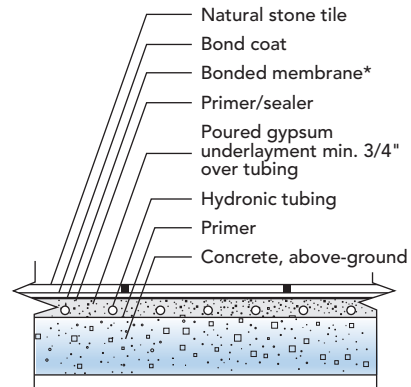

*Use of a membrane is required.
See membrane options.

Recommended Uses

For above ground structural slabs with a poured gypsum underlayment encapsulating hydronic tubing.

Application Over Plywood:

Maximum joist spacing shall be 16" on center. Plywood shall be Underlayment Exterior Grade or C-C Plugged Exterior Grade plywood (or better). If the existing floor is less than 1" thick, glue and nail 15/32" or 1/2" APA Underlayment Exterior Grade or C-C Plugged Exterior Grade plywood to the floor. Glue and nail using 5D or 6D (1 1/2" or 2") cement coated screw shank nails 6" on center along the panel edges and a maximum of 8" on center each way throughout the panel. Allow 1/8" gap between underlayment sheet edges and all areas that abut walls, drains, posts, etc., these areas shall be filled with mortar when tiles are installed. Clean and rough sand the plywood. Due to the limitations of plywood as a substrate, Bostik Big Tile & Stone™ is not intended for use on plywood in exterior, wet interior, or applications subject to heavy/commercial traffic.

RH122-16

- Joists 16" o.c./Plywood Subfloor
- Poured Gypsum Underlayment Encapsulating Hydronic Tubing
- Bonded Membrane
- Ceramic Tile, Natural Stone Tile

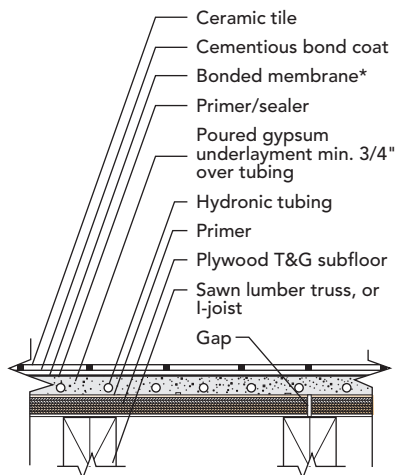

*Use of a membrane is required.
See membrane options.

Recommended Uses

For wood substrates with poured gypsum underlayment encapsulating hydronic tubing.

Interior Floors Over Plywood

F144-16 – F250-16

Joists 16" o.c./plywood

Cement Backer Board or Fiber-cement Backer board

Ceramic Tile

F144-16

- Joists 16" o.c./Plywood Subfloor
- Cement Backer Board or Fiber-Cement Backer Board
- Ceramic Tile, Natural Stone Tile

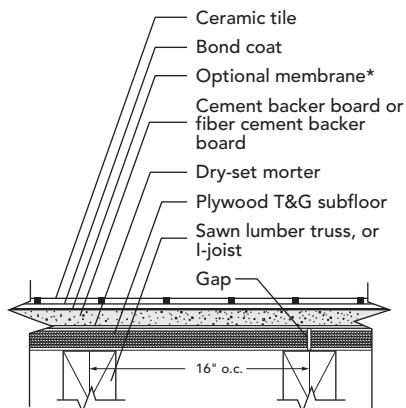

*Use of a membrane is optional.
See membrane options.

F250-16 STONE

- Joists 16" o.c./Plywood Subfloor
- Plywood Underlayment
- Backer Board
- Ceramic Tile, Natural Stone Tile

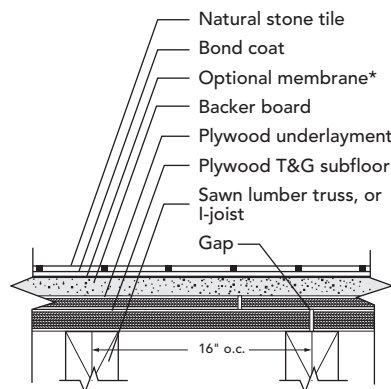

*Use of a membrane is optional.
See membrane options.

Installation of Ceramic Tile and Natural Stone Tile over Wood Subfloors.

F150-16

Joist 16" OC/Plywood Subfloor

Plywood Underlayment

Ceramic Tile

F150-16

- Joists 16" o.c./Plywood Subfloor
- Plywood Underlayment
- Ceramic Tile, Natural Stone Tile

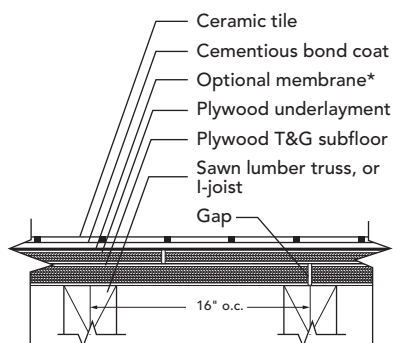

*Use of a membrane is optional.
See membrane options.

F250-16 STONE

- Joists 16" o.c./Plywood Subfloor
- Plywood Underlayment
- Backer Board
- Ceramic Tile, Natural Stone Tile

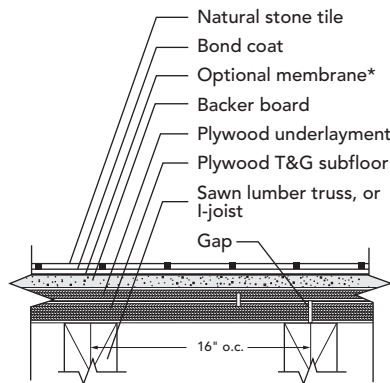

*Use of a membrane is optional.
See membrane options.

Recommended Uses:

For wood substrates where thin bed installation is desired.

Application Over Existing/VCT Flooring:

Vinyl must be clean and well bonded to substrate. Do not install over cushion-backed or perimeter bonded sheet vinyl. Remove any loose pieces of vinyl or flooring. Ensure the exposed substrate is suitable for the application. Some flooring and cutback adhesive may contain asbestos. Follow all Federal, state and local guidelines for proper removal. Refer to the Resilient Floor Covering Institute's "Recommended Work Practices for the Removal of Resilient Floor Coverings." Follow applicable ANSI, TCNA installation standards for exterior applications. Check with the materials manufacturer that all tiles, setting materials/mortars and grout are approved to be applied over existing VCT/Vinyl flooring.

Application Over Existing Ceramic Tile:

Tile must be clean and well bonded to substrate. Mechanical abrasion with Carborundum disk, followed by a clean water wash is recommended. Installation must be thoroughly rinsed and dry before setting the new tile.

STEP 4. Mixing and Spreading Thin / Medium Bed Mortar:

When working with any setting materials make sure that the temperature is at the setting material's manufacturer's guidelines — typically 50° – 100°F. When mixing follow the manufacturer's guidelines. Use a mixer suitable for the speed recommended e.g. 150rpm. Use clean potable water at the ratio indicated.

First spread the mortar with the flat edge of trowel, to achieve a good mechanical bond to the substrate.

Second apply additional mortar with the appropriate size notched trowel, keeping the trowel lines in one direction (raking and sliding tile to ensure proper coverage. If any evidence of skinning or setting occurs, remove and re-apply fresh mortar. Consult manufacturer's guidelines as to the amount of open time. Environmental variables (e.g. high or low relative humidity and temperature) can diminish the amount of open time depending upon geographical location.

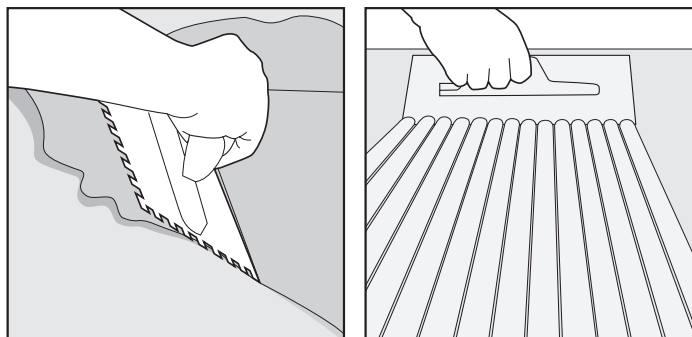

Periodically check back of tile to ensure proper transfer for interior applications — minimum 80% coverage. For exterior, wet, or plywood applications — minimum 95% coverage. For Stone the minimum coverage is 95% with no voids exceeding 2 square inches and no voids within 2" of the corners. Coverage is defined as the area the mortar makes contact with the tile and substrate.

If minimum coverage is not achieved, select a different trowel size.

Back Buttering

Although not required under TCNA guidelines, Large format Porcelain and Standard Porcelain tile may require back buttering prior to installation. There are some setting materials that may require this and some that negate this requirement. Check the mortar manufacturer's installation Guidelines / Technical Data Sheet (TDS) sheets for more information.

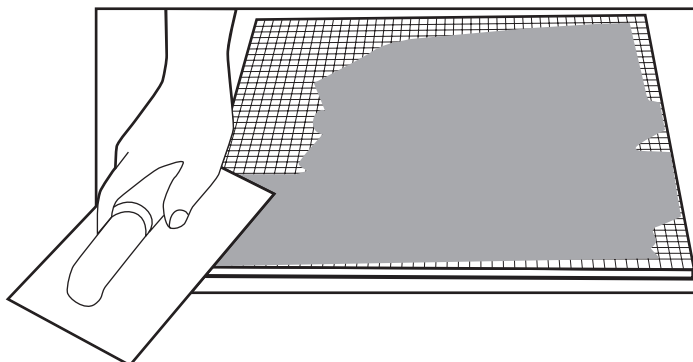

STEP 5. Setting the tile:

After spreading a sufficient quantity of thin set (medium) and checking transfer, start setting tiles as soon as possible to achieve the best bond. Apply tile using a twisting motion into a fresh bed of mortar to ensure maximum contact and bond. Depending on the project and the layout generally the field of full tiles will be set first and cuts installed the following day. It is also possible to precut all tiles or work with a helper to install cuts as the project proceeds.

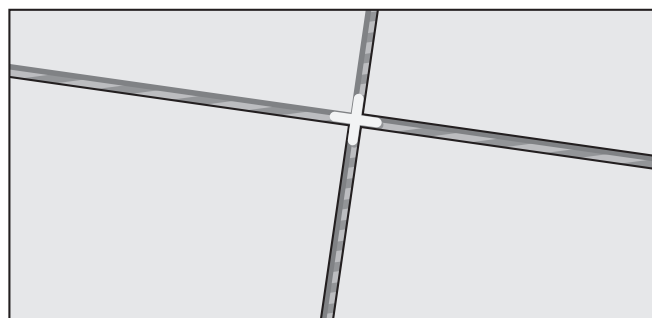
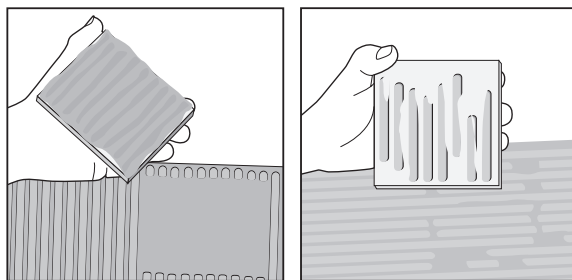

Spacers are generally used to set the width of the grout lines and keep the tiles spacing even.

For Large format Tiles it is recommended that Wedge Lippage System Spacers are used. To aid installation, suction cups may also be a great option to help handle the materials.

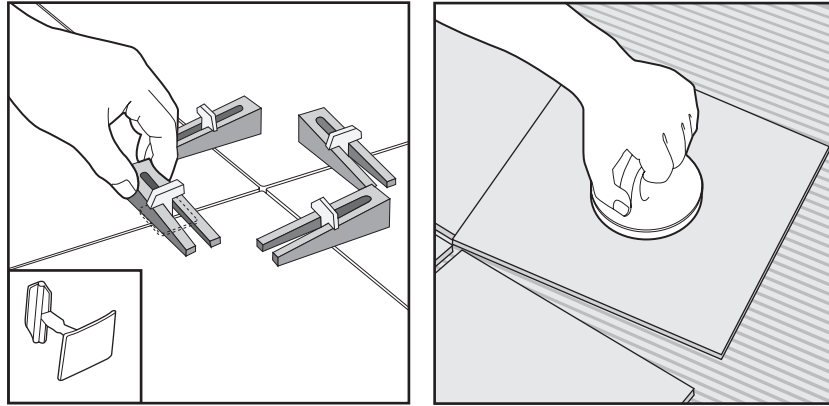

During the installation of the tiles, it is essential that excess setting materials are removed, both on the face of the tile and in the grout joint.

STEP 6. Grouting:

Unless setting material with rapid curing characteristics are used grouting will typically be performed the day after setting the tile.

Selection of a grout color that contrasts the tile color will emphasize the grout joint and any variation in tile size/ position. A similar color will de-emphasize these variations.

Take care when cleaning similar colored grout as sometimes grout haze will blend with the tile and make it difficult to see. Use appropriate grout float and clean tiles thoroughly.

Test stone to ensure that the grout will not stain. Stone may require sealing / enhancing before grouting.

Lumber Liquidators offer a number of solutions for grouting each has its own characteristics.

- 1) Neverseal – Urethane pre-mixed grout with lifetime stain resistance, superior crack protection and uniform color consistency.
- 2) Vivid - A stain resistant cementitious grout offers consistent color technology with enhanced stain and efflorescence protection.
- 3) Sanded Grout – A blend of carefully graded quartz aggregates, Portland cement, colorfast pigments and other special proprietary ingredients.

Whichever grout you choose always read and carefully follow the manufacture's Installation Guidelines / TDS sheets.

STEP 7. Finishing Up:

Seal or Enhance Stone

This last step is essential to the long term appearance of you installation. A good protective sealer makes soiling easier to clean and can prevent spills penetrating and staining your grout or stone.

Note: Marble is subseptable to "landing Marks" caused by spraying certain product, check manufacturer's guidelines / TDS sheets for more information.

When sealing or enhancing stone prepare a test sample to ensure that the product is giving you the result you are looking for.

Generally installation will follow some basic steps: (Always refer to the product manufactures installation guidelines / TDS sheets).

Install in an open ventilated environment with tempertaure and RH to manufacturer guidelines.

Floor surface is to be dry and free of contamination.

Remove all Grout haze from the tiles using a pH neutral cleaner e.g. Avella Haze Away.

Apply product using a sponge, paint pad or cotton towel.

Using absorbent paper or cotton towels, remove product that does not penetrate the surface, leaving excess product can leave a residue.

Apply second coat per manufacturer's guidelines / TDS sheets.

Sealing Grout:

Note: not all grout requires sealing. Please refer to the grout manufacturers installation guidelines and TDS sheets.

Generally installation will follow some basic steps: (Always refer to the product manufactures installation guidelines / TDS sheets).

1) Install in an open ventilated environment with tempertaure and RH to manufacturer guidelines.

2) Allow grout to dry for at least 24hours, Floor surface is to be dry and free of contamination

Remove all Grout haze from the tiles using a pH neutral cleaner e.g. Avella Haze Away.

Apply product using a grout sponge roller bottle applicator, low pressure spray, wet on wet application.

Remove product that does not soak while still wet: leaving excess product can leave a residue.

Mosaic Tile Installation:

Preparation: As per Tile and Stone

Cutting Tile Sheets to Fit:

In some cases, you will be able to cut fiberglass mesh using a sharp utility knife to create fill cuts for your needs, but in other situations, you may need to trim the individual edge tiles to fit using a wet saw or diamond grinder.

Begin Installation at the Center

1. Refer to page 15 for layout details.
2. Start in the center where the layout lines intersect, apply a layer of thin-set adhesive to one of the four sections, working in areas about 2 to 4 feet square. See product TDS sheet for proper trowel notch.

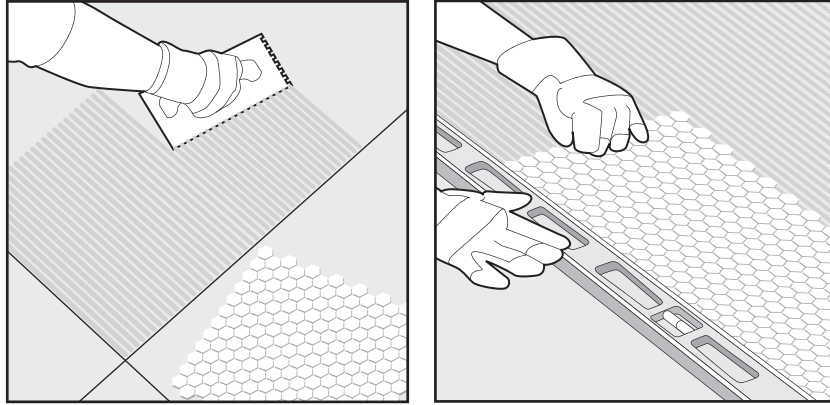

3. Apply one sheet of mosaic tile into the corner of the center lines., adjust tile ensure it is square with the layout lines. Press firmly to press the tile into the thin-set.
4. Install adjoining mosaic sheets in the same manner, always use tile spacers to keep gaps between sheets the same as the gaps between tiles within the sheets.
5. Once the initial section is complete, apply thin-set and install tiles in the remaining three uninstalled sections. Work outward from the center until all full sheets of tile are installed.

Mosaic sheets can form waves on the surface. To prevent this, during installation, use a small piece of plywood about 6-8 inches square and a rubber mallet to tap the mosaics into the thin-set.

This will flatten the tile, creating a nice smooth surface. Pay attention to the edges between sheets, to avoid lippage where one row of tiles is higher than the adjoining row.

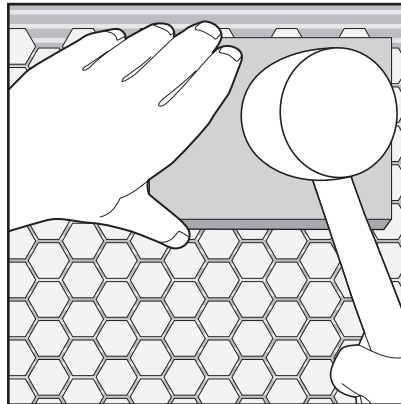

[HOME * WARRANTY * CARE](#)

Care and Maintenance

Cleaning Glazed Porcelain and Ceramic

Glazed porcelain and ceramic tiles are among the easiest flooring materials to clean.

Due to their impenetrable glazes, their surfaces are resistant to water, dirt, chemicals, oil, debris, and even germs and bacteria.

Always Remember:

1. Protect your tile from sand and grit as floors may scratch from debris.
 2. Sweep or vacuum loose dirt and dust from the floor prior to washing with water to prevent the tile from becoming muddy or leaving a residue after cleaning. On textured surfaces sweep in multiple directions to ensure the removal of all foreign material that might be residing in the textured surface. For wall surfaces tile can be gently wiped down with a clean, dry cloth or rag.
 3. Damp-mop your tile floor at least once each week (more frequently for heavy traffic areas) with a mild detergent, degreaser, or tile cleaning solution to decrease wear and abrasion from grit and soil.
 4. For textured floors, the use of a medium bristle brush is recommended. A sponge or clean cloth can be used to apply the cleaning agent to wall surfaces.
 5. Clean the floor with a mild detergent or a pH neutral tile cleaning solution such as Avella Ultra Deep Cleaner.
 6. Rinse the tile thoroughly with clean water to remove any left-over detergents.
 7. Drying with a clean cloth or rag is recommended to increase the shine and to prevent water spots or Streaks.
- Do not use wax or oil-based cleaners.
 - Do not clean porcelain tile flooring with ammonia or with cleaners that contain bleach and/or acid. Acid and ammonia-based cleaners may modify grout color and product stability.
 - Do not use steel wool or other abrasive pads to remove tough debris or stains. Steel wool may scratch your tiles and loose steel particles may eventually create rust stains in the grout overtime.
 - Although glazed surfaces are impervious, the use of a grout release will aid in post installation clean up, especially if the glazed surface has a texture to it where mortar, grout and other construction debris can get trapped inside grooves during and after installation.
 - Replace hard plastic caster wheels with softer wide rubber wheels.
 - Use rugs at entrances to prevent dirt and grit from being tracked onto the tile flooring from outdoors. Tiles are scratch resistant but not scratch proof.

Standard Cleaning Guidelines for Natural Stone

Natural stone is a very durable surface when protected and maintained properly and is widely used in residential and commercial applications.

Always Remember, in addition to the care requirements above:

- Protect against stains - It is recommended that a breathable penetrating tile sealer such as (Avella Ultra-Premium Stone and Tile Sealer) be applied to the surface of the stone prior to installation and after grouting.
- Follow the manufacturer's guidelines for recommendations on how often a sealer should be reapplied,
- Clean the floor with a mild detergent or pH neutral cleaning solution specifically designed for stone such as such as (Avella Ultra Deep Cleaner) safe for all sealed natural stone.
- Dry with a clean cloth or rag to prevent water spots or streaks.
- Do not clean natural stone with ammonia or with cleaners that contain bleach and/or acid.
- Do not use vinegar and water as this can etch into the sealer and stone.
- Be careful with acidic foods and drinks (lemonade, orange juice, etc.) as they may etch certain stones.
- Never apply wax or acrylics to the surface as they may damage the stone.
- Remove spills quickly. Sealers do not prevent 100% of damages caused by spills.

Cleaning grout

- Grout can absorb soaps and stains, do not clean with oil or wax based cleaners (Murphy's Oil soap, Pine Sol, etc.). These products will leave a waxy, sticky or oily film in the grout.
Use a pH neutral grout cleaner made specifically for this purpose such as (Avella Ultra Deep Cleaner). Safe for Urethane, and cement based grouts as well as sealed natural stone.
- Read entire label before using.
- For best results vacuum or sweep surface to be cleaned, making sure to remove all loose debris.
- Apply the solution over the grout joints to be cleaned and allow to stand for 2-3 minutes.
- Agitate with a soft bristle brush primarily in heavily soiled areas.
- Solution should be changed as needed.
- Mop with clean water to remove any leftover cleaner.

What Not to Do

- Never use a product containing ammonia or bleach (or any type of acid-based cleanser); these can alter the tile color and/or stain the grout.
- On unglazed porcelain, never use any cleaners that contain dye or coloring.
- Never use steel wool to clean porcelain tile—small particles of steel can become embedded in the tile and grout, eventually causing rust stains.
- Never use hard bristles or scrub brushes, as they can scratch the tile surface.
- Any cleaners containing acid or bleach shouldn't be used for routine maintenance.
- Avoid wax-based cleaners and oil-based detergents, and use sealants on grout joints only.
- Harsh cleaning aids like steel wool pads or any scouring pads containing metal shouldn't be used on tile.
- Unglazed tile should not be cleaned with an agent that contains color.

Extra Protection

Invest in high-quality all-natural floor mats (plastic and solvent-free) and protective pads under chair legs and heavy furniture for an extra layer of protection to your tile floors. Place floor mats at entrances and exits to collect and trap corrosive substances that can be tracked in, like dirt, sand, oil, grit, asphalt, or even driveway sealer. Placing mats in high-traffic areas—in front of vanities, kitchen sinks, and stoves—is an effective way to reduce tile wear.

[HOME * WARRANTY * INSTALLATION](#)